

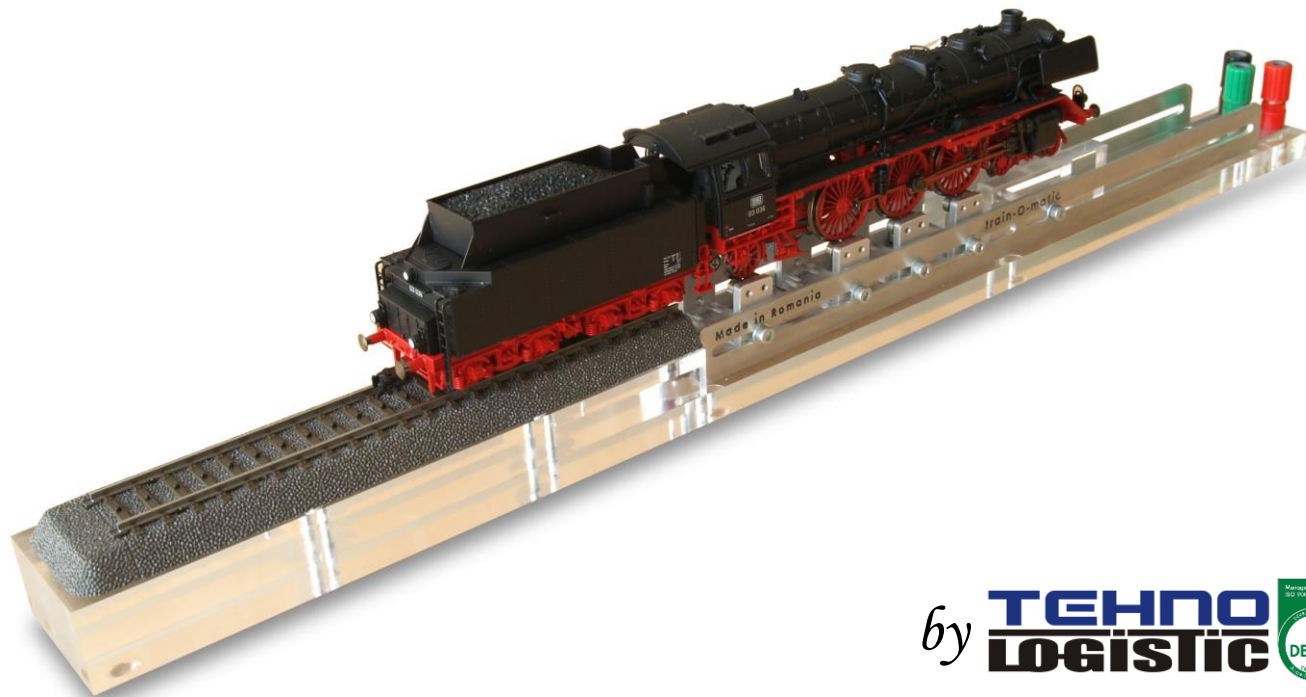

# Roller Tester

User Manual  
version 0.0.1





# Roller Tester

## User Manual

Version 0.0.1

---

**© Copyright 2012 Tehnologistic SRL**  
**All rights reserved**

No part of this publication may be reproduced or transmitted in any form or by any means, electronic or mechanical, including photocopying, without the written permission of  
SC Tehnologistic SRL  
Subject to technical modification



Please read this manual carefully before carrying out the installation!!! Although our products are very robust, incorrect wiring may destroy tester!

The metal parts of the tester, including the roller blocks, have the electrical potential of the voltage applied to the tracks. You should therefore always turn the power supply voltage OFF, or switch the command station to Emergency position before touching these parts!



---

## Table of Contents

1. Features .....	3
2. Technical parameters .....	4
3. Package Content .....	4
4. Components of the Roller Tester .....	5
5. Removing the 3 <sup>rd</sup> Central Rail .....	6
6. Adjusting the Roller Blocks .....	7
7. Adding and removing Roller Blocks and supports .....	8
8. Connecting an AC Current transformer for 3 rail operation .....	9
9. Connecting Marklin Digital for 3 rail operation .....	10
10. Connecting a DC power transformer for 2 rail operation .....	11
11. Connecting a DCC Command station for 2 rail operation .....	12
12. Accessories.....	13

## 1. Features

The tOm roller tester is a suitable for drive and testing of H0 vehicles in AC/DC/DCC systems with 2 or 3 rail connections. It is delivered with 4 Roller Blocks (for use with driven axes) and 2 different length plastic supports . The unit also contains a 2 rail / central rail fixed track section for supporting the powered but not driven axes. Further Roller Blocks can be added on request (partnumber tOm 03100102). Special knurled thumb screws for the roller blocks are also available as option (partnumber tOm 04100101).



## 2. Technical parameters

- |   |           |
|---|-----------|
| - Maximal track voltage applied to the tester | 24V AC/DC |
| - Overall length of the Roller Tester         | 500 mm    |
| - Usable length                               | 445 mm    |

## 3. Package Content

The tOm Roller Tester is delivered in a carton box, packed in bubble foil protection. Check when unpacking the product if the following parts are present:

- Roller tester 1 pcs
- Roller Blocks 4 pcs
- Plastic supports 2 pairs
- Allen (HEX) key 1 pcs



## 4. Components of the Roller Tester

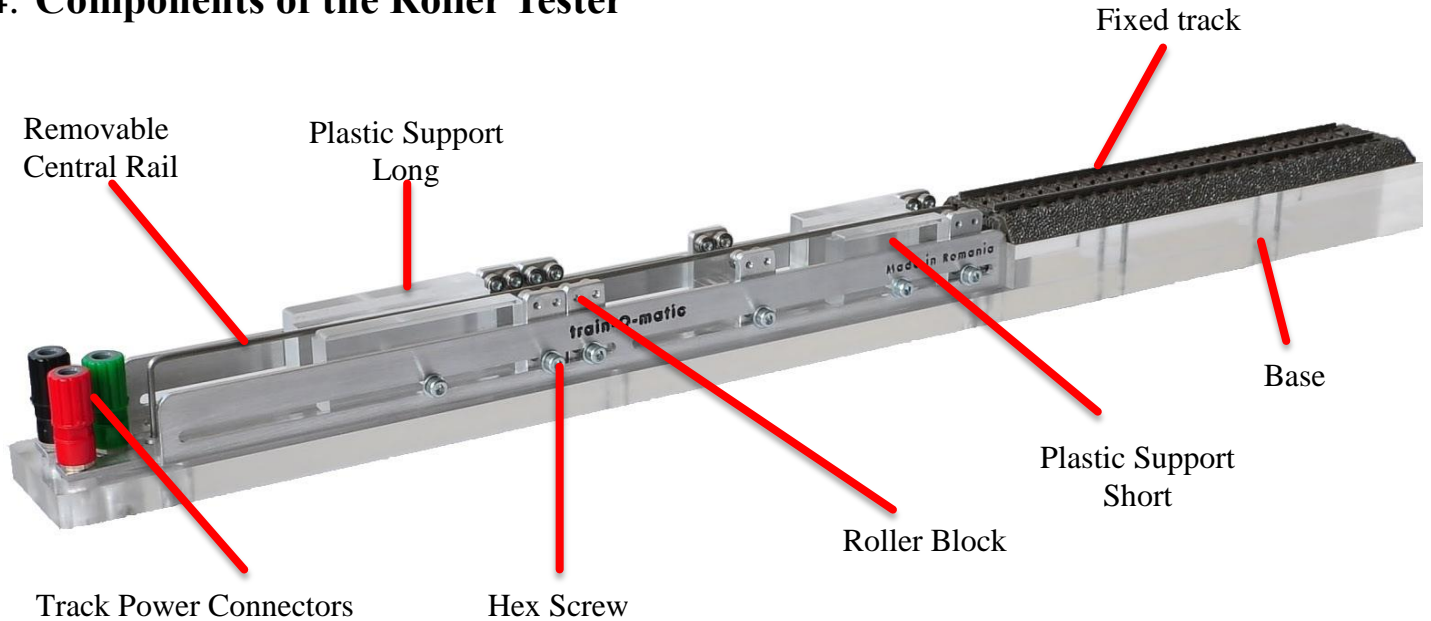



## 5. Removing the 3<sup>rd</sup> Central Rail

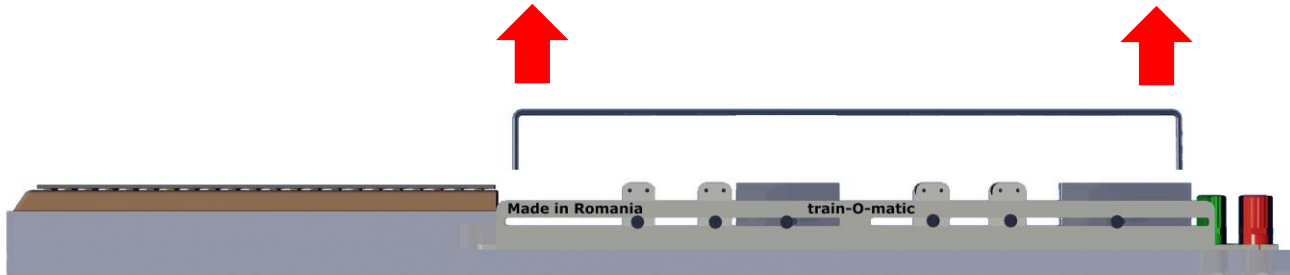



## 6. Adjusting the Roller Blocks

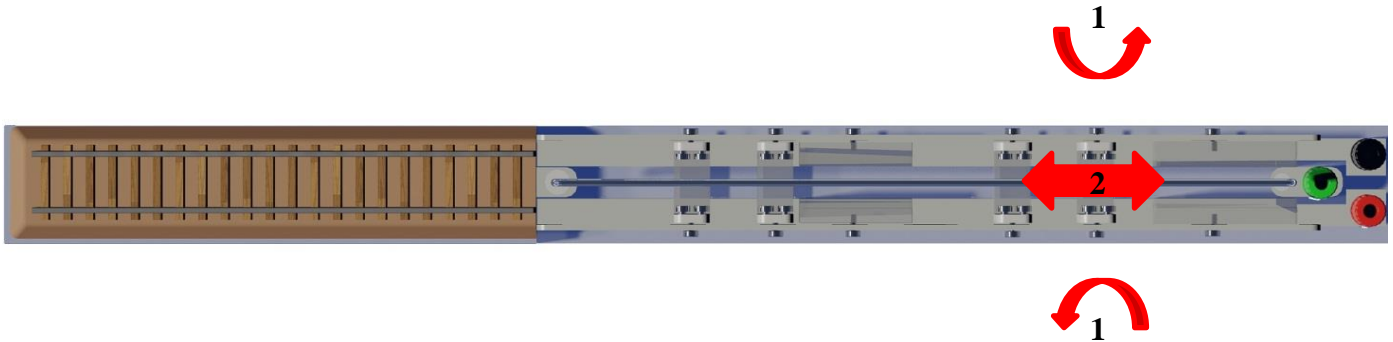

## 7. Adding and removing Roller Blocks and supports

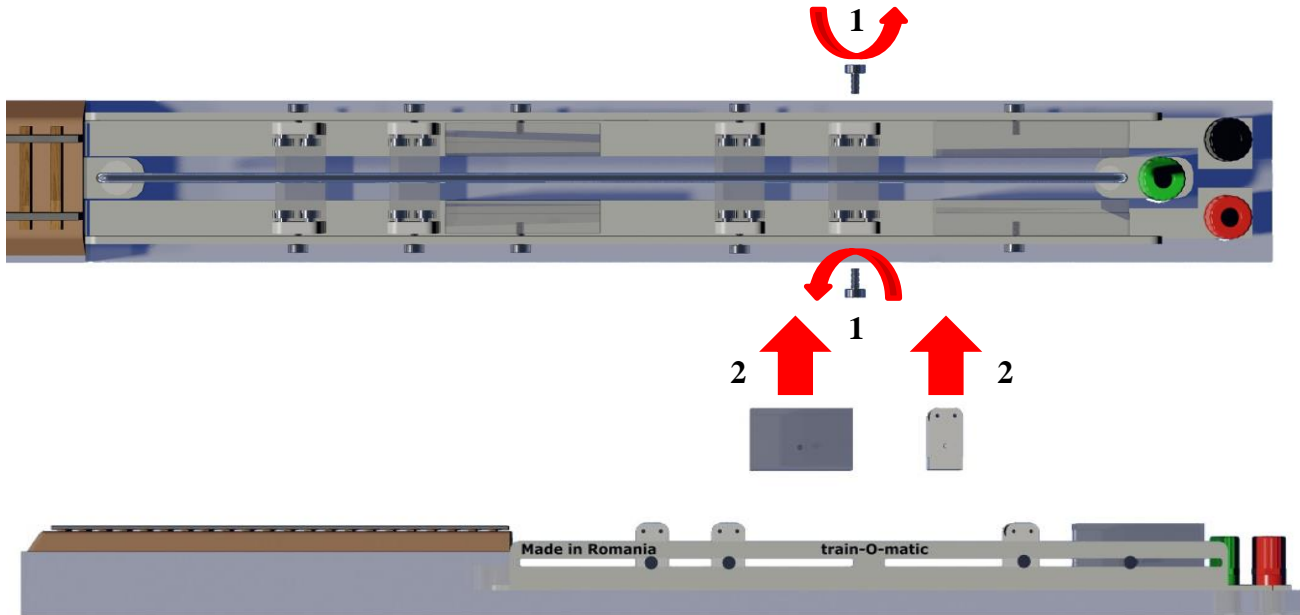





## 8. Connecting an AC Current transformer for 3 rail operation

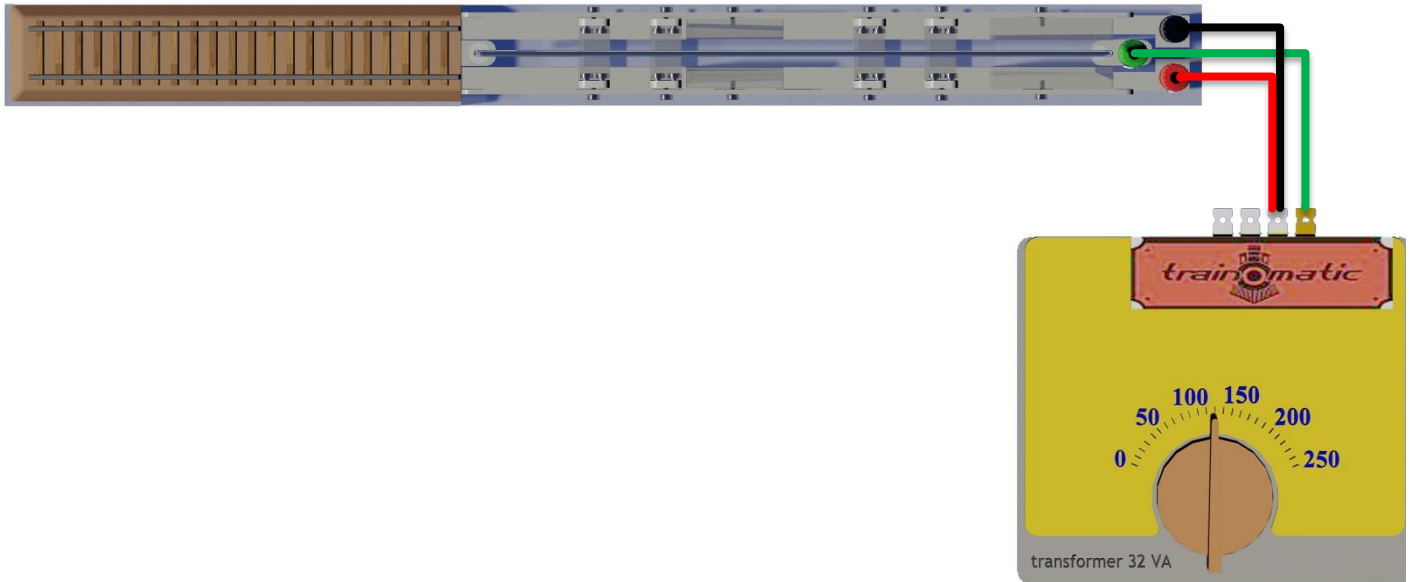



## 9. Connecting Marklin Digital for 3 rail operation

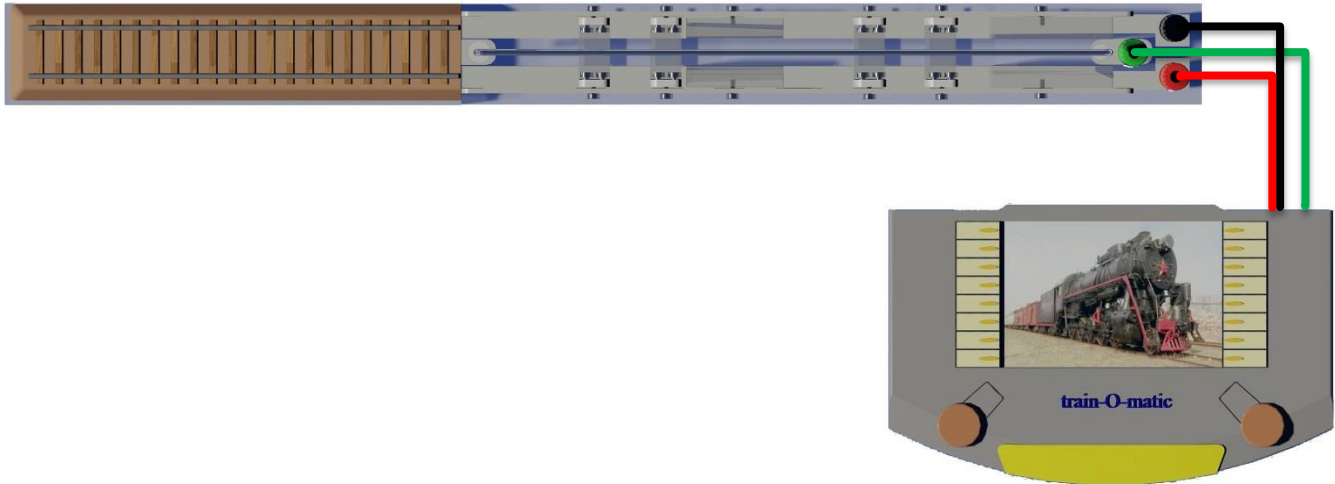



## 10. Connecting a DC power transformer for 2 rail operation

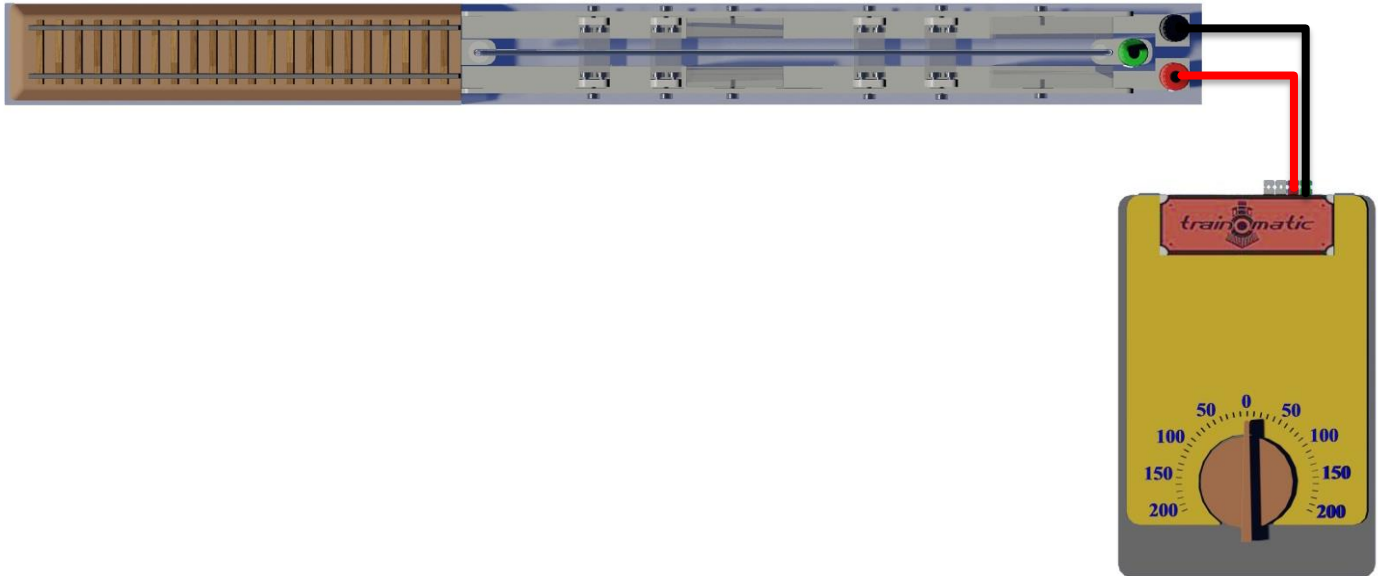



## 11. Connecting a DCC Command station for 2 rail operation

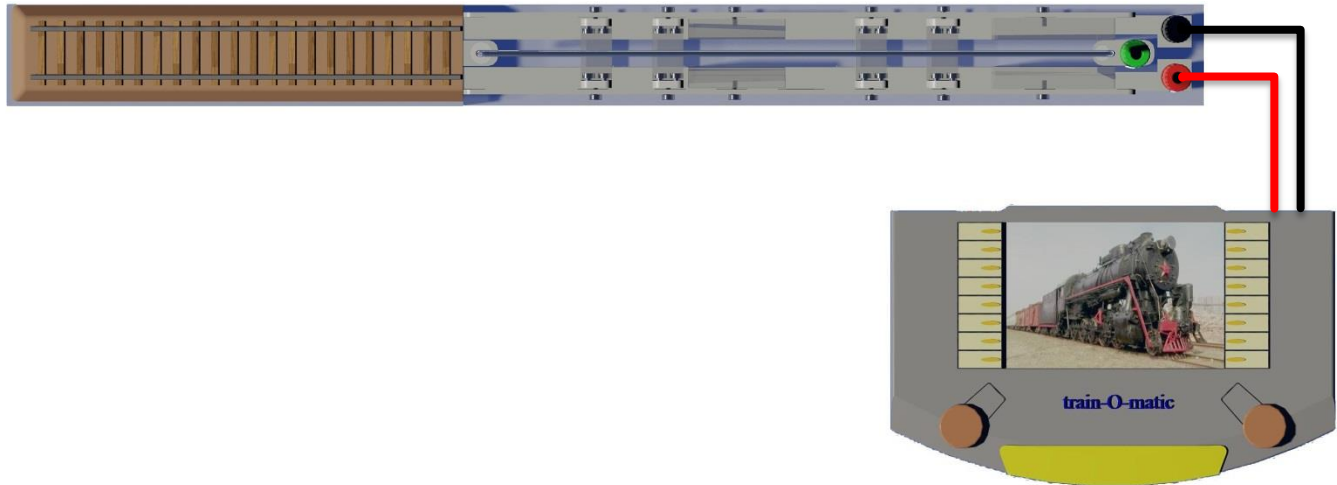

## 12. Accesories

Additional Roller Blocks  
partnumber :  
tOm 03100102

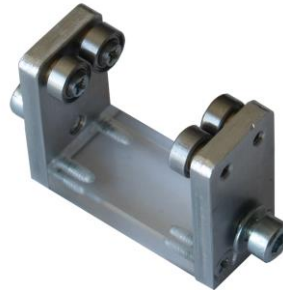

Special knurled thumb screws for the roller blocks  
Partnumber:  
tOm 04100101





# Roller Tester

## User Manual

Version 0.0.1

**Copyright © 2013 Tehnologistic SRL**  
**All rights reserved**  
**The information in this document is subject to change without notice**



“train-o-matic” and the  logo are registered trademarks of SC Tehnologistic SRL  
[www.train-o-matic.com](http://www.train-o-matic.com)  
[www.tehnologistic.ro](http://www.tehnologistic.ro)

**Tehnologistic SRL**  
**Str. Libertatii Nr. 35A**  
**407035 Apahida, Cluj**  
**Romania**

**Tel +40-264-556454**  
**Fax +40-264-441275**

